

NMAX Sports Screen

BLS-261C0-**



00:06



| Posnr. | QTY | |
|--------|-----|--|
| ① | 1 | |

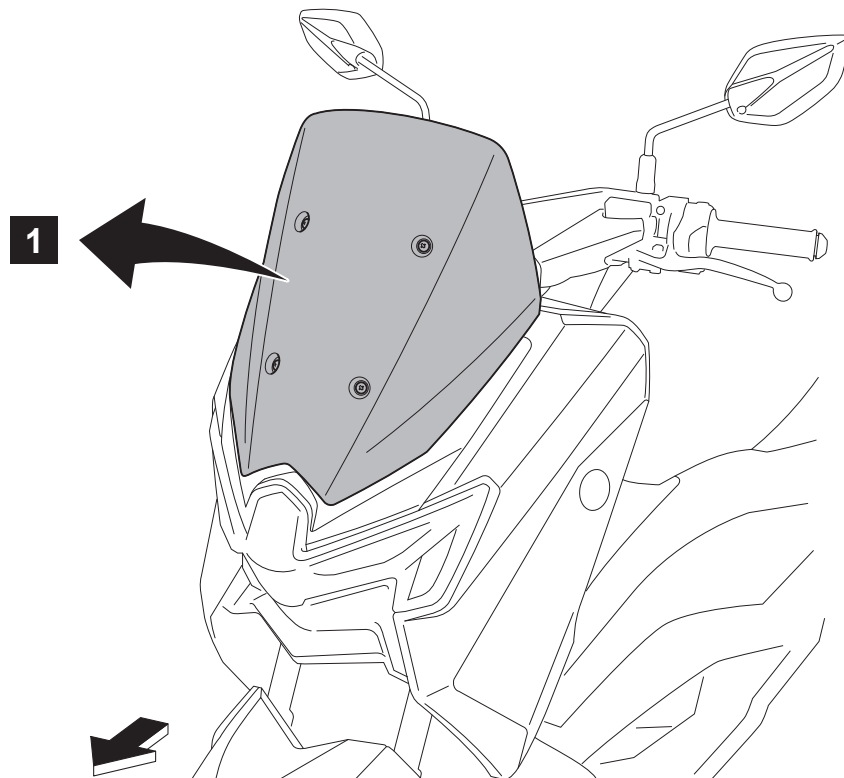

| | | | | |
|--|---|---|--|---|
| <p>Easy, suitable for novice with little experience</p> | <p>Fairly easy, suitable for beginner with some experience</p> | <p>Fairly difficult, suitable for competent DIY mechanic</p> | <p>Difficult, suitable for experienced DIY mechanic</p> | <p>Very difficult, suitable for expert DIY or professional</p> |
|--|---|---|--|---|



NMAX Sports Screen

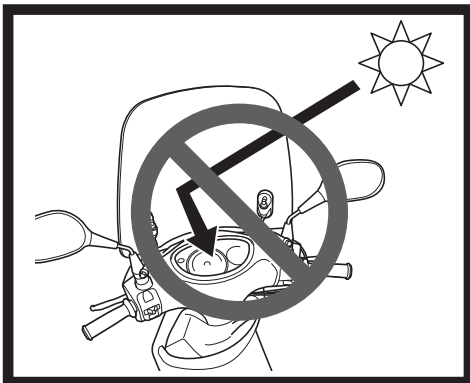
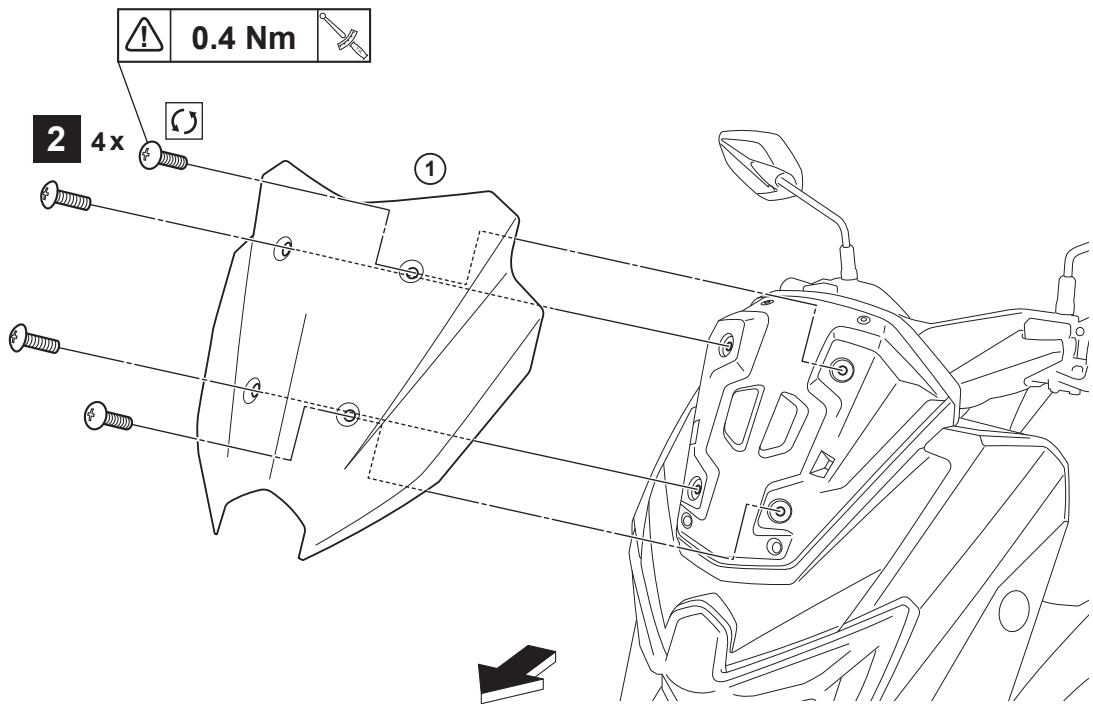

NOTICE

Do not park your motorcycle in such a way that sunlight strikes the screen from the rear. This is because the screen is likely to act as a concave mirror which reflects and concentrates the light, causing the cover and nearby parts of your motorcycle to become deformed. If it is unavoidably necessary to park in direct sunlight, cover the screen with a soft cloth, or the like.

ATTENTION

Ne stationnez pas votre moto de telle manière que la lumière du soleil vienne frapper l'écran par l'arrière. Ceci parce que l'écran est susceptible de réagir en tant que miroir concave qui réfléchit et concentre la lumière, ceci entraînant une déformation du couvercle et des pièces voisines de votre moto. S'il est inévitablement nécessaire de se garer en exposition directe à la lumière du soleil, couvrez l'écran avec un tissu souple ou du même type.

ACHTUNG

Parken Sie Ihr Motorrad nicht so, dass Sonnenlicht von hinten auf die Scheibe fällt. Der Grund dafür liegt darin, dass die Scheibe wie ein Hohlspiegel wirkt, der Licht reflektiert und bündelt, so dass die Abdeckung und in der Nähe liegende Teile Ihres Motorrads verformt werden. Falls es unumgänglich notwendig ist, in direktem Sonnenlicht zu parken, decken Sie die Scheibe mit einem weichen Tuch oder dergleichen ab.

ATTENZIONE

Non parcheggiare la motocicletta in luoghi dove la luce del sole possa colpire il parabrezza dal retro. Questo perché il parabrezza potrebbe agire come uno specchio concavo che riflette e concentra la luce, causando la deformazione della copertura e delle zone vicine. Se è assolutamente necessario parcheggiare la moto alla luce diretta del sole, coprire il parabrezza con un panno morbido o qualcosa di simile.

ATENCIÓN

No estacione la motocicleta en modo tal que el sol incida en la pantalla desde atrás. Esto porque la pantalla se comporta como un espejo cóncavo que refleja y concentra la luz haciendo que la cubierta y las partes cercanas de la motocicleta se deformen. Si no se puede absolutamente evitar estacionar a la luz solar directa, cubra la pantalla con un paño suave o algo similar.